

KOMATSU®

PC138US-8

HORSEPOWER
Gross: 72.1 kW 96.6 HP / 2200 min⁻¹
Net: 68.4 kW 91.7 HP / 2200 min⁻¹

OPERATING WEIGHT
13480–13850 kg

BUCKET CAPACITY
0.18–0.60 m³

ecot3

PC
138us



Photo may include optional equipment.

HYDRAULIC EXCAVATOR

WALK-AROUND

Komatsu's PC138US-8 Series Hydraulic Excavators have a short tail swing profile, designed specifically for work in confined areas. By reducing tail swing, the PC138US-8 is perfect for work on road ways, bridges, in urban areas, or anywhere space is limited. The PC138US-8 Series provides the performance and productivity you expect from Komatsu equipment.

Ecology and Economy Features

● ***Low Emission Engine***

A powerful turbocharged and air-to-air aftercooled Komatsu SAA4D95LE-5 provides 68.4 kW 91.7 HP. This engine is U.S. EPA Tier 3 and EU Stage 3A emissions certified without sacrificing power or machine productivity.

● ***Low Operation Noise***

The dynamic noise is reduced providing low noise operation.

See page 4.

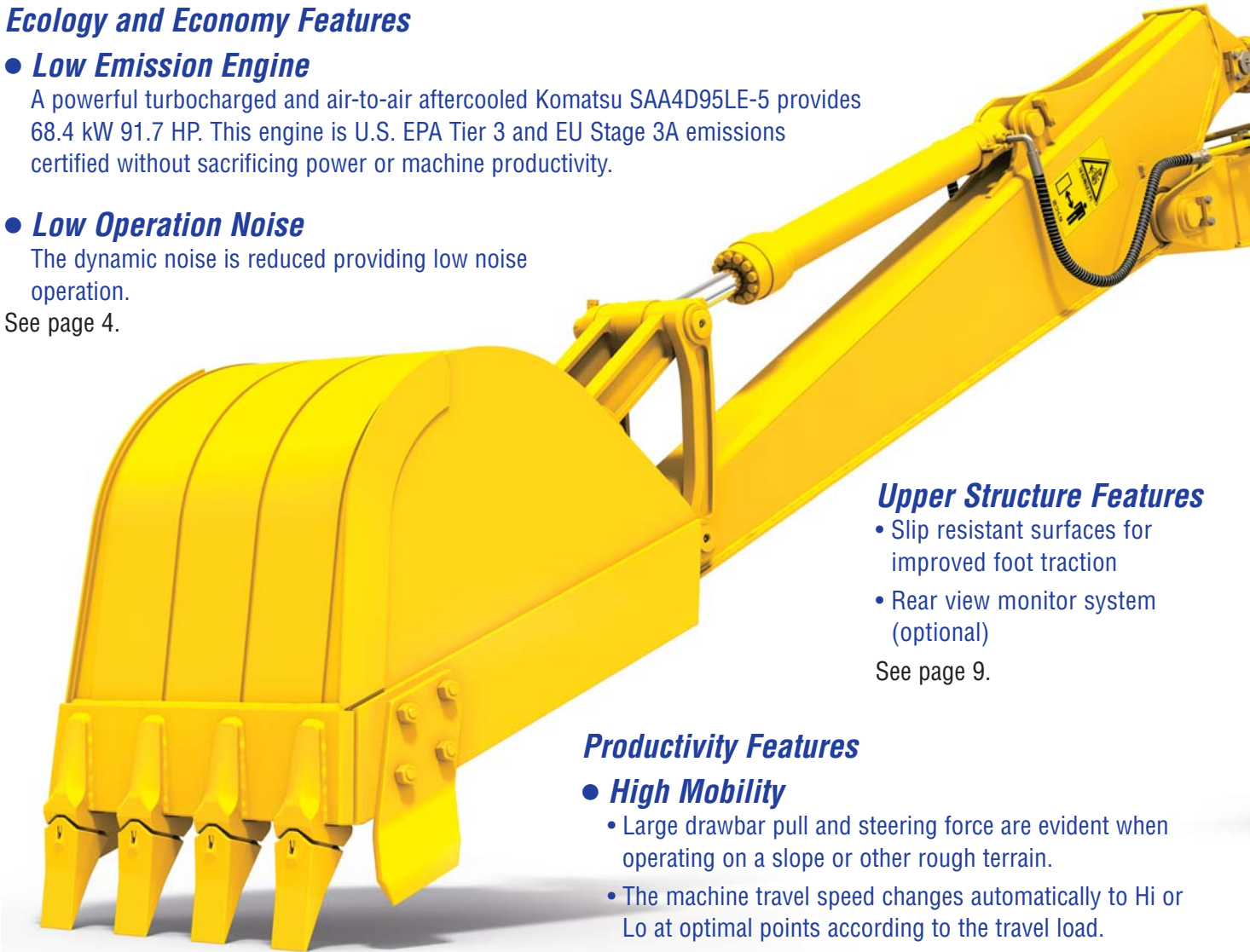

Upper Structure Features

- Slip resistant surfaces for improved foot traction
- Rear view monitor system (optional)

See page 9.

Productivity Features

● ***High Mobility***

- Large drawbar pull and steering force are evident when operating on a slope or other rough terrain.
- The machine travel speed changes automatically to Hi or Lo at optimal points according to the travel load.

See page 5.

● ***High Stability***

The PC138US-8 offers exceptional lifting capacity and high stability with a large counterweight.

See page 5.

● ***Mode Selection***

- Five working modes designed to match engine speed, pump delivery and system pressure.

See page 5.

Operation Features

● **Small Tail Swing**

- Excellent operation in tight quarters with small tail swing radius design
- Round profile provides short protrusion of front and rear portion of the upper structure.
- Occupies small road width for operation on narrow roads.

See pages 6 and 7.

- **Wider Working Ranges** : Job sites that require a long upper reach, such as demolition and slope cutting also benefit from the increased digging and dumping ranges of the PC138US-8.

See page 7.



Photo may include optional equipment.

HORSEPOWER

Gross: 72.1 kW 96.6 HP / 2200 min⁻¹

Net: 68.4 kW 91.7 HP / 2200 min⁻¹

OPERATING WEIGHT

13480 – 13850 kg

BUCKET CAPACITY

0.18 – 0.60 m³

Large Liquid Crystal Display (LCD) Monitor

- Easy-to-see and use 7" large multi-function color monitor
- Can be displayed in 12 languages for global support.

See page 11.

Large Comfortable Cab

- ROPS cab (ISO 12117-2)
- Low noise cab design with viscous cab mounting
- Sliding convex door facilitates easy entrance in confined areas.
- Large cab improves working space.

See page 8.

Easy Maintenance

- Long replacement interval of hydraulic oil and hydraulic filter
- Remote mounted engine oil filter and fuel drain valve for easy access
- Equipped with the fuel pre-filter as standard (with water separator)
- Side-by-side cooling function enables only the cooling unit to be attached and detached.
- Equipped with the Equipment Management Monitoring System.

See pages 10 and 11.

Excellent Reliability and Durability

- High rigidity work equipment
- Sturdy frame structure
- Reliable Komatsu manufactured major components

See page 11.

PRODUCTIVITY & ECOLOGY FEATURES

Komatsu Technology



Komatsu develops and produces all major components in house such as engines, electronics and hydraulic components. Combining “Komatsu Technology”, and customer feedback, Komatsu is achieving great advancements in technology. To achieve both high levels of productivity and economical performance, Komatsu has developed the main components with a total control system. The result is a new generation of high performance and environment-friendly excavators.

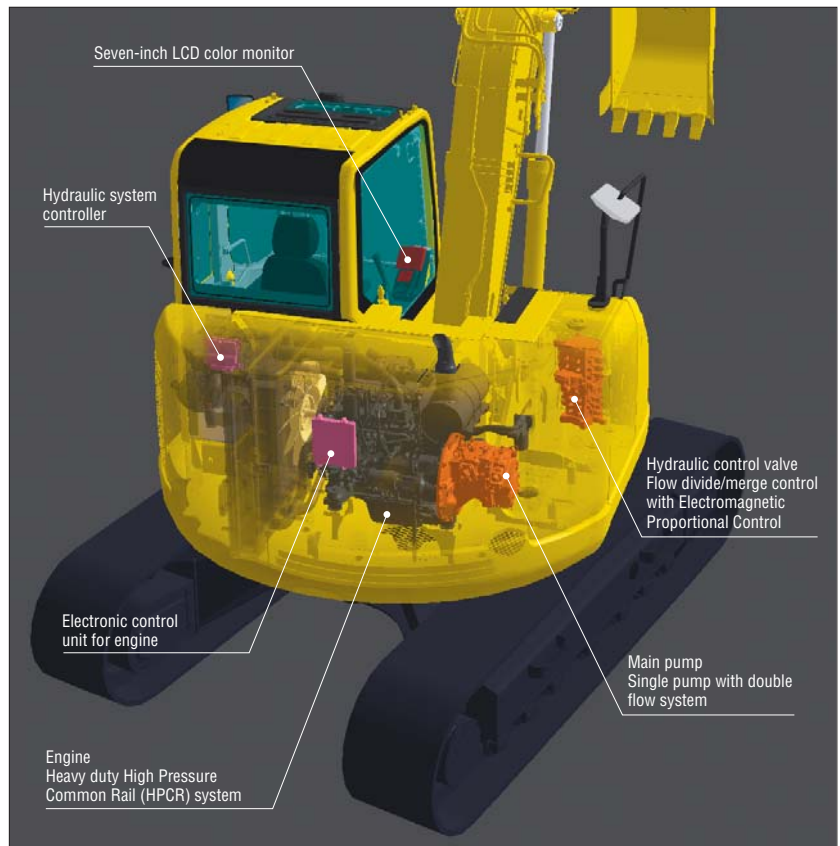

Low Emission Engine

Komatsu SAA4D95LE-5 engine is U.S. EPA Tier 3 and EU Stage 3A emissions certified.

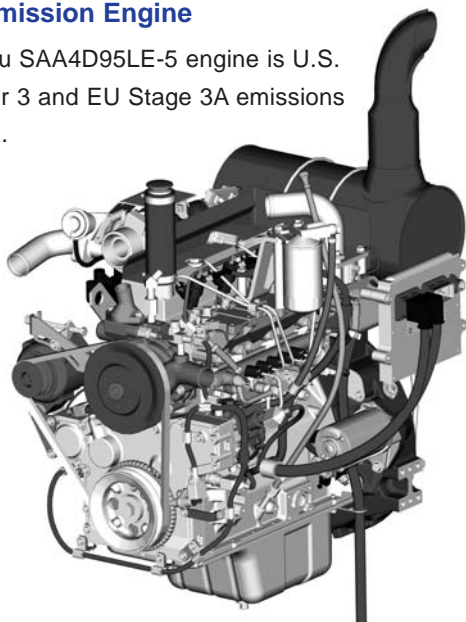

Low Operation Noise

Enables low noise operation using the low-noise engine and methods to cut noise at source.

Electronically controlled common rail type engine

- Multi-staged injection

Low noise design

- Optimal arrangement of sound absorbing materials
- Partition between the cab and engine room
- Airtight valve room



Large Digging Force

The PC138US-8 has a large bucket digging force and arm crowd force, that facilitates digging hard rock-bed.

	PC138US-8	PC120-6*
Bucket digging force (ISO 6015 rating)	93.2 kN 9500 kgf	93.4 kN 9520 kgf
Arm crowd force (ISO 6015 rating)	61.8 kN 6300 kgf	63.7 kN 6500 kgf

*PC120-6 measured with power max.

High Mobility

The PC138US-8 exceptional travel performance is provided by single pump with double flow, and it demonstrates superb maneuverability while operating at its optimum travel speed. It exhibits a large drawbar pull for moving on job sites, traveling in rough terrain and climbing steep slopes.



High Stability

The PC138US-8 offers exceptional lifting capacity and high stability with a large cast-iron counterweight that requires no additional clearance.

	PC138US-8	PC120-6
Lifting capacity*	1290 kg	1150 kg
Weight of counterweight	3250 kg	2255 kg

*At maximum reach, ground level height and over-side.



Working Modes Selectable

The PC138US-8 excavator is equipped with five working modes (P, E, L, B and ATT mode). Each mode is designed to match engine speed and pump speed with the current application. This provides the flexibility to match equipment performance to the job at hand.

Working Mode	Application	Advantage
P	Power mode	<ul style="list-style-type: none"> Maximum production/power Fast cycle times
E	Economy mode	<ul style="list-style-type: none"> Good cycle times Better fuel economy
L	Lifting mode	<ul style="list-style-type: none"> Suitable attachment speed
B	Breaker mode	<ul style="list-style-type: none"> Optimum engine rpm, hydraulic flow
ATT	Attachment mode	<ul style="list-style-type: none"> Optimum engine rpm, hydraulic flow, 2way

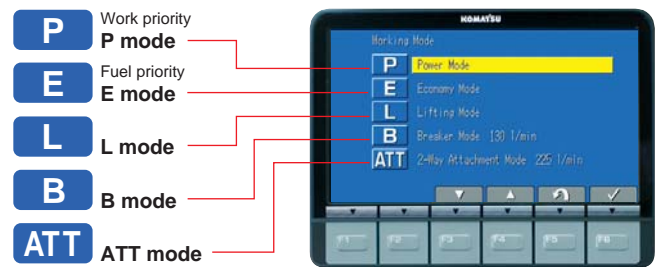

ECO Gauge that Assists Energy-saving Operations

The ECO gauge on the right side of the multi-function color monitor provides environment-friendly energy-saving operation. Allows focus on operation in the green range with reduced CO2 emissions and efficient fuel consumption.



Idling Caution

To prevent unnecessary fuel consumption, an idling caution is displayed on the monitor, if the engine idles for 5 minutes or more.



OPERATION FEATURES

Safe Operation with Small Tail Swing Even in Confined Areas

Short Implement Swing Radius:

1980 mm boom raising angle of the PC138US-8 is larger than a conventional machine. The result is reduced front implement swing radius.

Minimum implement swing radius 1980 mm



Short Tail Swing Radius:

1480 mm The short tail swing radius of the PC138US-8 allows the machine to work in more confined areas than a conventional machine.

Tail swing radius 1480 mm

Roadwork

When performing roadwork, protrusion of the machine into the unoccupied lane is kept minimal since the rear portion of the upper structure protrudes slightly from the track at swing. This allows a dump truck to be positioned closer to the track of the machine. The operator is able to load materials efficiently onto the front of the dump body at ease since ample dumping reach is assured for the loading. Large working space is not required for the machine.

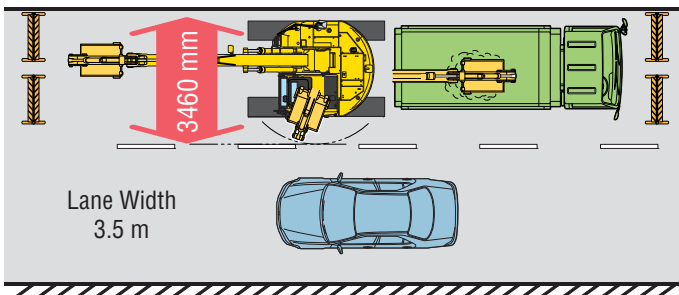

Logging and forest roadwork

Since the protrusion of the rear portion of the upper structure is kept minimal, there is less possibility of the counterweight hitting against a tree or a slope, allowing the operator to operate the machine at ease. Furthermore, large digging height facilitates slope finishing work. Large drawbar pull assures smooth and powerful traveling even on rough terrain.

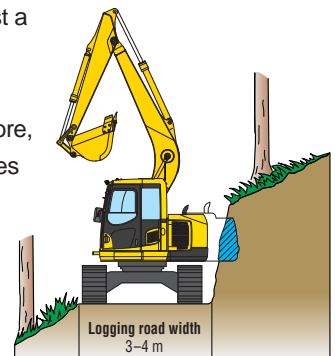

Demolition

The machine needs less working space and can perform efficient demolition work since it has large and ample digging height.

Wider Working Ranges

Raising the boom on the PC138US-8 to a wider angle enhances overall working performance. Job sites that require a long upper reach, such as demolition and slope cutting, also benefit from the increased digging and dumping ranges of the PC138US-8.

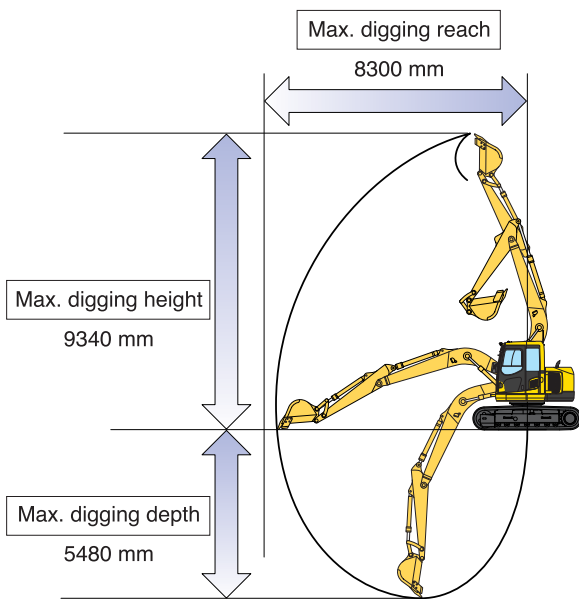

Maximum digging height	9340 mm
Maximum digging depth	5480 mm
Maximum dumping height	6840 mm

Round Profile of both Front and Rear Portion of the Upper Structure

Komatsu hydraulic excavators with small tail swing radius design adopt the round profile for both left and right corners of the front portion of the upper structure as well as its rear portion that features less protrusion from the track at swing. The round profile design allows the machine to work in tight quarters.

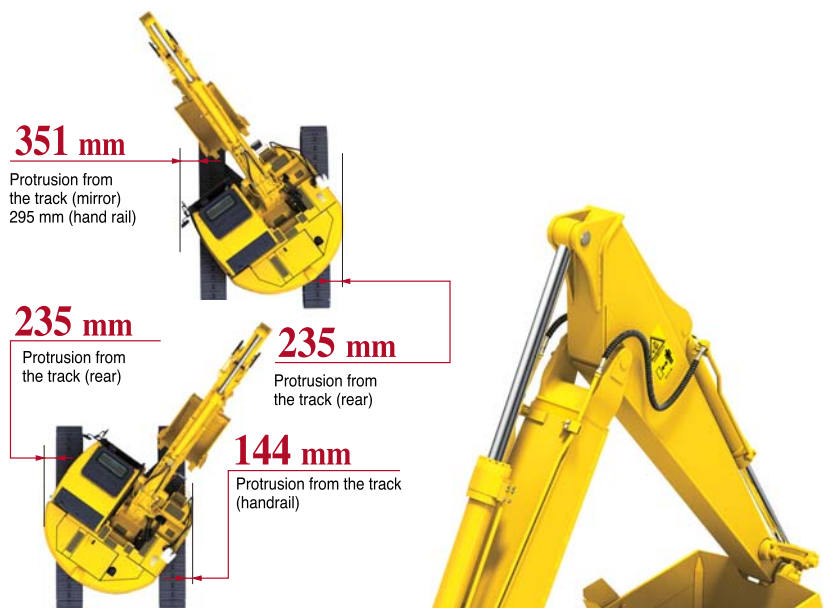

Photo may include optional equipment.

WORKING ENVIRONMENT

PC138US-8 cab interior is spacious and provides a comfortable working environment...

Large Comfortable Cab

Multi-position Controls

The multi-position, Pressure Proportional Control (PPC) levers allow the operator to work in comfort while maintaining precise control. A double-slide mechanism allows the seat and controllers to move together or independently, allowing the operator to position the seat and controllers for maximum productivity and comfort.

Low Cab Noise

Cab is highly rigid and has excellent sound absorption ability. Thorough improvement of noise source reduction and use of low noise engine, hydraulic equipment, and air conditioner (A/C) allows this machine to generate a low level of noise.

Comfortable Ride with Viscous Cab Mounts

Viscous mounts are adopted for cab mount system. The cab mount system absorbs shocks and aids vibration reduction to provide comfortable ride.

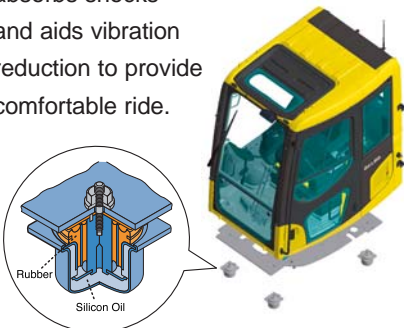

Pressurized Cab

Automatic A/C, air filter and a higher internal air pressure prevent external dust from entering the cab.



Large Cab

Large cab provides ample operation space. The cab has wide doorway for easy access.



Automatic A/C

Automatic A/C is utilized. The bi-level control function keeps the operator's head and feet cool and warm respectively. This improved air flow function keeps the inside of the cab comfortable throughout the year. Defroster function keeps cab glass clear.

Sliding Convex Door

The sliding convex door facilitates easy entrance in confined areas.



Features

ROPS Cab

The machine is equipped with a ROPS cab that conforms to ISO 12117-2 for excavators as standard equipment. The ROPS cab has high shock-absorption performance, featuring excellent durability and impact strength. It also satisfies the requirements of ISO 10262 OPG top guard level 1 for falling objects. Combined with the retractable seat belt, The ROPS cab protects the operator in case of tipping over and against falling objects.



Retractable Seat Belt

Easy-to-use retractable seat belt is employed.



Tempered and Tinted Glass

The glass features high strength and blocks ultraviolet rays.

Emergency Escape Hammer

The cab is equipped with an emergency escape hammer for breaking the rear window glass in case of an emergency.

Travel Alarm

An alarm is installed as standard equipment to give other workers a warning when the machine travels in forward or reverse.

Pump/engine Room Partition

Pump/engine room partition prevents oil from spraying on the engine if a hydraulic hose should burst.

Slip-resistant Plates

Highly durable slip resistant plates maintain superior foot traction performance.



Lock Lever

When lock lever is placed in lock position all hydraulic controls (travel, swing, boom, arm and bucket) are inoperable.



Lever shown in lock position

Rear View Monitor System (optional)



The operator can view the rear of the machine with a color monitor screen.

Monitor for rear view camera



Wide Visibility

The right side window pillar has been removed and the rear pillar reshaped to provide improved visibility.



Skylight

Skylight with window can be opened for overhead visibility.



MAINTENANCE FEATURES

Easy Maintenance

Komatsu designed the PC138US-8 to have easy service access. By doing so, routine maintenance and servicing are less likely to be skipped, which can mean a reduction in costly downtime later on. Here are some of the many service features found on the PC138US-8.

Optimum Maintenance Layout

With the left and right side service doors, it is possible to access the major maintenance points from ground level. Furthermore, the fuel drain valve, engine oil filter, swing machinery oil filler, and Power Take Off (PTO) oil filler are remote mounted, facilitating easy maintenance.

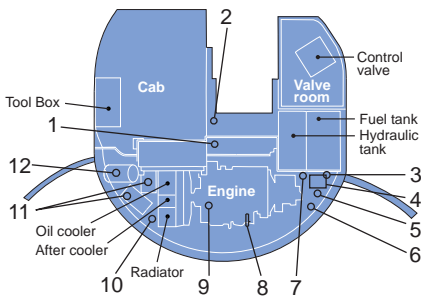

- 1. Swing machinery oil filler
- 2. Swing machinery dip stick
- 3. Fuel filter (with water separator)
- 4. Coolant reserve tank
- 5. Fuel drain valve
- 6. PTO oil filler
- 7. Engine oil filter
- 8. Engine oil dipstick
- 9. Engine oil filler
- 10. Windshield washer tank
- 11. Batteries
- 12. Air cleaner

Equipped with the Fuel Pre-filter (with Water Separator)

Removes water and contaminants in the fuel to prevent fuel problems.



Washable Floor

The PC138US-8's floor is easy to keep clean. The gently inclined surface has a flanged floor mat and drainage holes to facilitate run off.



Side-by-side Cooling

The oil cooler, aftercooler and radiator are installed side by side. As a result, it is very easy to clean the radiator, etc. In addition, the operator can remove and install the aftercooler, radiator and oil cooler in a short time.

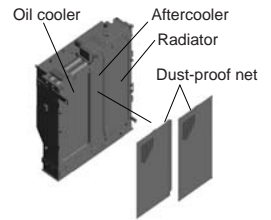

Large Tool Box

Large tool box provides plenty of space. Grease pump storage space is also provided.



Photo may include optional equipment.

Maintenance Costs Reduced

Hydraulic Filter Element

High performance filters are used in the hydraulic circuit and engine. Longer hydraulic oil, hydraulic oil filter, engine oil and engine oil filter element replacement intervals significantly reduce maintenance costs.

- Engine oil & Engine oil filter** every **500** hours
- Hydraulic oil** every **5000** hours
- Hydraulic oil filter** every **1000** hours



Long Greasing Interval

Special hard material is used for the bushings of the work equipment to lengthen greasing interval. All bushing lubrication intervals of work equipment except arm top bushing are 500 hours, reducing maintenance costs.

Large LCD Monitor

Large multi-lingual LCD Monitor

A large user-friendly color monitor enables safe, accurate and smooth work. Improved screen visibility is achieved by the use of LCD that can easily be read at various angles and lighting conditions. Simple and easy to operate switches. Industry first function keys facilitate multi-function operations. Displays data in 12 languages to globally support operators around the world.



- Indicators**
- 1 Auto-decelerator
 - 2 Working mode
 - 3 Travel speed
 - 4 Engine water temperature gauge
 - 5 Hydraulic oil temperature gauge
 - 6 Fuel gauge
 - 7 ECO gauge
 - 8 Function switches menu
- Basic operation switches**
- 1 Auto-decelerator
 - 2 Working mode selector
 - 3 Traveling selector
 - 4 Buzzer cancel
 - 5 Wiper
 - 6 Windshield washer

Equipment Management Monitoring System

Monitor function

Controller monitors engine oil level, coolant temperature and battery charge, etc. If controller finds any abnormality, it is displayed on the LCD.



Maintenance function

Monitor informs replacement time of oil and filters on LCD when the replacement interval is reached.



Trouble data memory function

Monitor stores abnormalities for effective troubleshooting.

Excellent Reliability and Durability

High Rigidity Work Equipment

Boom and arms are constructed of thick plates of high tensile strength steel. In addition, these structures are designed with large cross-sectional areas and generous use of castings. The result is working attachments that exhibit long term durability and high resistance to bending and torsional stress.

Sturdy Frame Structure

The revolving frame, center frame and undercarriage are designed by using the most advanced three-dimensional CAD and Finite Element Method (FEM) analysis technology.

Metal Guard Rings Protect all the Hydraulic Cylinders and Improve Reliability.

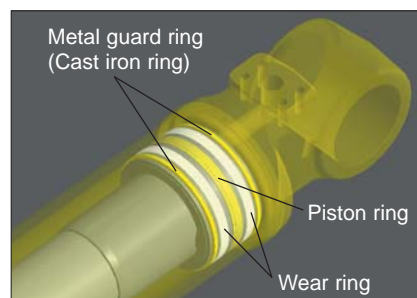

Reliable Components

All of the major machine components, such as engine, hydraulic pump, hydraulic motors and control valves are exclusively designed and manufactured by Komatsu.

Sealed Connectors

Sealed connectors seal tight and have higher reliability.

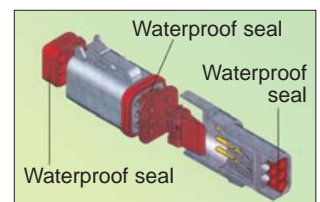

O-ring Face Seal

The hydraulic hose seal method has been changed from a conventional taper seal to an O-ring seal. This provides improved sealing performance.

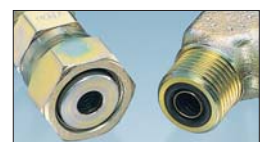



DIMENSIONS

Boom Length		4600 mm	4600 mm	4600 mm
Arm Length		2500 mm	3000 mm	2100 mm
A	Overall length	7260 mm	7160 mm	7275 mm
B	Overall height (to top of boom)	2850 mm	3210 mm	2690 mm
C	Length on ground (transport)	4400 mm	4290 mm	4660 mm

D	Overall width	2490 mm
E	Overall height (to top of cab)	2815 mm
F	Ground clearance, counterweight	900 mm
G	Minimum ground clearance	395 mm
H	Tail swing radius	1480 mm
I	Length of track on ground	2880 mm
J	Track length	3610 mm
K	Track gauge	1990 mm
L	Width of crawler	2490 mm
M	Shoe width	500 mm
N	Grouser height	20 mm
O	Machine cab height	1980 mm
P	Machine cab width	2490 mm
Q	Distance swing center to rear end	1480 mm

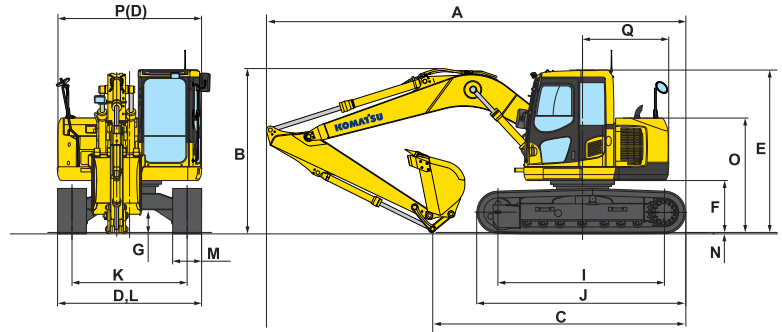
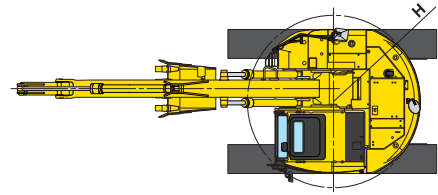

WORKING RANGE

Boom		4600 mm	4600 mm	4600 mm
Arm		2500 mm	3000 mm	2100 mm
A	Maximum digging height	9340 mm	9700 mm	9020 mm
B	Maximum dumping height	6840 mm	7350 mm	6525 mm
C	Maximum digging depth	5480 mm	5900 mm	5070 mm
D	Maximum vertical wall digging depth	4900 mm	5340 mm	4490 mm
E	Maximum digging depth of cut for 2440 mm level	5265 mm	5715 mm	4830 mm
F	Maximum digging reach	8300 mm	8720 mm	7930 mm
G	Maximum digging reach at ground	8180 mm	8600 mm	7805 mm
H	Minimum swing radius	1980 mm	2265 mm	1845 mm
ISO 6015 Rating	Bucket digging force	93.2 kN 9500 kgf	88.3 kN 9000 kgf	88.3 kN 9000 kgf
	Arm crowd force	61.8 kN 6300 kgf	55.9 kN 5700 kgf	71.6 kN 7300 kgf
	Bucket digging force	81.4 kN 8300 kgf	78.0 kN 7950 kgf	78.0 kN 7950 kgf
SAE 1179 Rating	Bucket digging force	60.8 kN 6200 kgf	54.4 kN 5550 kgf	69.6 kN 7100 kgf

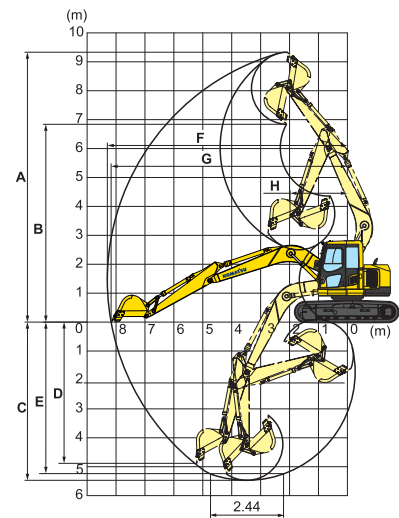

BACKHOE BUCKET AND ARM COMBINATION

Bucket Capacity (heaped)		Width		Weight	Number of Teeth	Arm Length		
ISO 7451, PCSA	CECE	Without Side Cutters	With Side Cutters			2500 mm	3000 mm	2100 mm
0.18 m ³	0.16 m ³	450 mm	570 mm	256 kg	3	○	○	○
0.28 m ³	0.26 m ³	600 mm	720 mm	303 kg	3	○	○	○
0.36 m ³	0.33 m ³	700 mm	820 mm	330 kg	4	○	○	○
0.50 m ³	0.45 m ³	859 mm	979 mm	399 kg	4	○	X	○
0.60 m ³	0.55 m ³	1000 mm	NA	436 kg	5	□	X	□

○—General digging □—Light-duty operation X— Not available



LIFTING CAPACITY

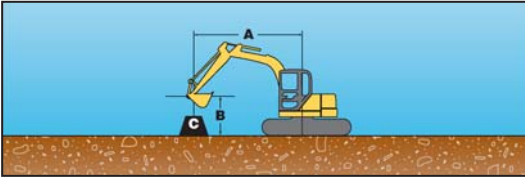

Equipment:

- Boom: 4.6 m
- Bucket: 0.50 m³
- Counterweight: 3250 kg

- A: Reach from swing circle
- B: Bucket hook height
- C: Lifting capacity
- Cf: Rating over front
- Cs: Rating over side
- ⊗: Rating at maximum reach

PC138US-8		Shoe: 500 mm		Arm: 2.5 m		Unit: kg			
B	A	3.0 m		4.6 m		6.1 m		⊗ Maximum	
		Cf	Cs	Cf	Cs	Cf	Cs	Cf	Cs
6.1 m				*3060	*3060			*1690	*1690
3.0 m		*5770	*5770	*4320	2990	2880	1830	*1580	1370
0.0 m		*5630	4840	4260	2600	2690	1660	*1940	1290
-3.0 m		*6040	4820	4180	2540			3000	1850

PC138US-8		Shoe: 500 mm		Arm: 3.0 m		Unit: kg			
B	A	3.0 m		4.6 m		6.1 m		⊗ Maximum	
		Cf	Cs	Cf	Cs	Cf	Cs	Cf	Cs
6.1 m				*2690	*2690	*1580	*1580	*1380	*1380
3.0 m		*3690	*3690	*3740	3040	2900	1850	*1280	1200
0.0 m		*5990	4830	4240	2580	2670	1640	*1530	1120
-3.0 m		*5990	4680	4100	2450	2620	1590	2510	1530

PC138US-8		Shoe: 500 mm		Arm: 2.1 m		Unit: kg			
B	A	3.0 m		4.6 m		6.1 m		⊗ Maximum	
		Cf	Cs	Cf	Cs	Cf	Cs	Cf	Cs
6.1 m				*3240	3120			*2100	*2100
3.0 m		*6480	5720	*4630	2940	2850	1810	*1950	1510
0.0 m		*5570	4800	4240	2590	2700	1670	2310	1420
-3.0 m		*6270	4880	4230	2580			3500	2160

* Load is limited by hydraulic capacity rather than tipping. Ratings are based on ISO 10567. Rated loads do not exceed 87% of hydraulic lift capacity or 75% of tipping load.



STANDARD EQUIPMENT

- Air cleaner, double element with auto dust evacuator
- Alternator, 24 V/35 A
- Auto A/C
- Auto deceleration
- Batteries, 2 x 12 V/64 Ah
- Cab which includes: antenna, AM/FM radio, floor mat, intermittent front windshield wiper and washer, large ceiling hatch, pull-up front window, removable lower windshield, sliding rear window, sliding seat
- Cooling fan, mixed flow with fan guard
- Counterweight, 3250 kg
- Dustproof net for radiator and oil cooler
- Light, one front
- Monitor panel
- Pump/engine partition cover
- ROPS cab (ISO 12117-2)
- Shoe, 500 mm triple grouser
- Starting motor 4.5 kW
- Swing holding brake
- Travel alarm



OPTIONAL EQUIPMENT

- Additional counterweight (500 kg)
- Additional filter system for poor-quality fuel
- Alternator, 24 V/60A
- Arm, 2100 mm
- Arm, 3000 mm
- Blade assembly (Bolt-on cutting edge type)
- Blade assembly (Welded cutting edge type)
- Hydraulic control unit
 - 1 additional actuator
- Rear view monitor system
- Shoes
 - 600 mm triple grouser
 - 700 mm triple grouser
 - 500 mm rubber pad (Road liner)
- Track frame undercover
- Track roller guard
- Travel motor (Increased drawbar pull type)

Up to 20% blended paraffine fuel can be used. Please consult your Komatsu distributor for detail.

<https://home.komatsu/en/>

Printed in Japan 202004 IP.As

The image shows the Komatsu logo, which consists of the word "KOMATSU" in a bold, blue, sans-serif font. A registered trademark symbol (®) is located to the upper right of the letter "U". The logo is positioned in the top-left corner of a large, empty rectangular box that occupies the lower half of the page.